

- UNIVERSAL CARTRIDGE DESIGN
- HAST-C BELLOW CORE BY DEFAULT
- INHERENTLY PRESSURE BALANCED
- NO SHAFT FRETTING
- FITS ON ANSI, ISO & DIN PUMPS
- BIG BORE VERSION AVAILABLE
- USES STANDARD COMPONENT SEAL

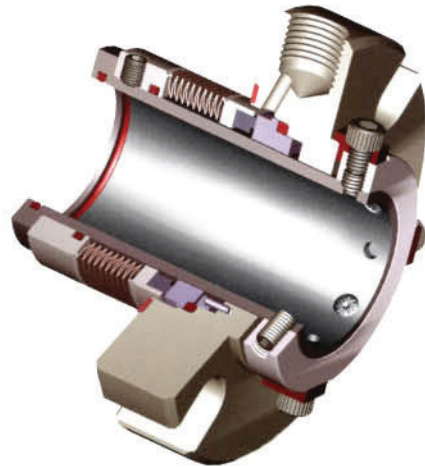

APPLICATIONS :

- CHEMICALS & SALT SOLUTIONS
- PETROCHEMICALS
- REFINERIES
- PULP & PAPER INDUSTRIES



LIMITING PARAMETERS

PRESSURE	TEMPERATURE	SPEED
UPTO 20 BAR	- 70°C TO 280°C DEPENDING UPON ELASTOMER	26 m/sec

MATERIALS

BELLOWS	METAL PARTS	FACE COMBINATIONS		ELASTOMERS
		ROTARY	STATIONARY	
HAST-C (STD) INCONEL, ALLOY-20 AM-350	SS316 (STD) HAST-C, ALLOY-20 CARPENTER-42	CARBON	SiC, TC	VITON, EPR PTFE, GFT AFLAS, KALREZ, FEP
		SiC	SiC	
		TC	SiC, TC	

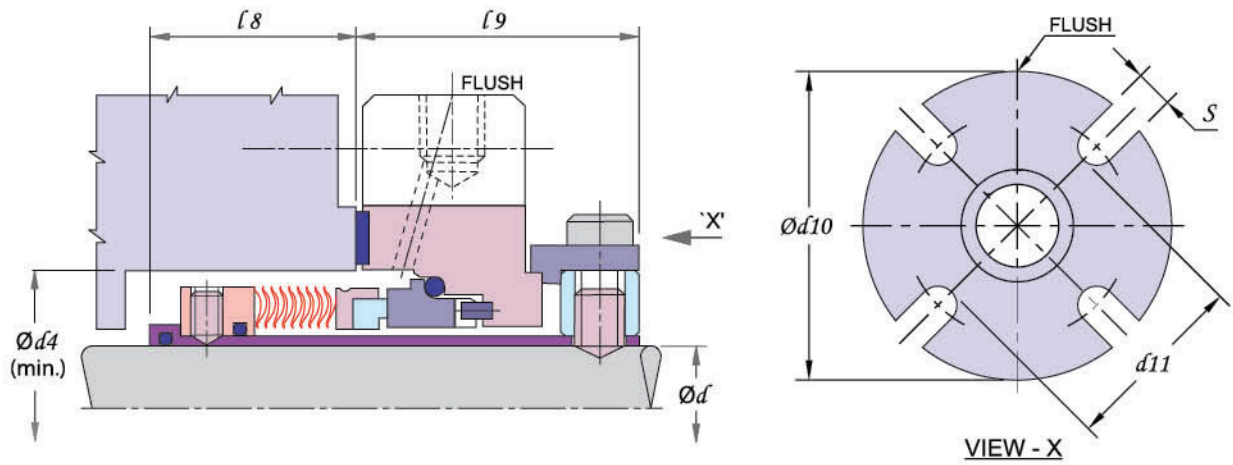

INCH SIZES

SIZE CODE	d	d4	d10	d11	l8	l9	SLOT WIDTH S
0254	25.40	44.45	101.6	56.5	35.15	37.1	14.0
0285	28.57	44.45	105.0	61.5	36.72	37.1	14.0
0317	31.75	50.80	108.0	63.5	39.90	37.1	14.0
0349	34.92	50.80	108.0	68.5	39.90	37.1	14.0
0381	38.10	57.15	114.3	71.5	39.90	37.1	14.0
0412	41.27	60.32	114.3	75.5	39.90	37.1	14.0
0444	44.45	63.50	127.0	77.8	41.50	37.1	14.0
0476	47.62	66.67	133.4	81.0	41.50	37.1	14.0

SIZE CODE	d	d4	d10	d11	l8	l9	SLOT WIDTH S
0508	50.80	69.85	139.7	84.0	41.50	37.1	14.0
0539	53.97	73.02	146.0	89.0	41.50	37.1	18.0
0571	57.15	76.20	165.1	92.0	43.10	37.1	18.0
0603	60.32	82.50	165.1	97.0	43.10	37.1	18.0
0635	63.50	85.72	165.1	101.0	44.70	41.2	18.0
0666	66.67	88.90	177.8	103.0	44.70	41.2	18.0
0698	69.85	93.70	177.8	111.0	46.20	41.2	18.0
0762	76.20	101.6	190.0	129.0	46.20	45.0	18.0

ALL DIMENSIONS IN MM

METRIC SIZES

SIZE CODE	d	d4	d10	d11	l8	l9	SLOT WIDTH S
0250	25.0	44.0	101.6	56.5	35.15	37.1	14.0
0280	28.0	44.0	105.0	61.5	36.72	37.1	14.0
0300	30.0	51.0	108.0	63.5	39.90	37.1	14.0
0320	32.0	51.0	108.0	63.5	39.90	37.1	14.0
0330	33.0	51.0	108.0	68.5	39.90	37.1	14.0
0350	35.0	51.0	108.0	68.5	39.90	37.1	14.0
0380	38.0	57.2	114.3	71.5	39.90	37.1	14.0
0400	40.0	60.5	114.3	75.5	39.90	37.1	14.0
0430	43.0	63.5	127.0	77.8	41.50	37.1	14.0
0450	45.0	63.5	127.0	77.8	41.50	37.1	14.0

SIZE CODE	d	d4	d10	d11	l8	l9	SLOT WIDTH S
0480	48.0	66.7	133.4	81.0	41.50	37.1	14.0
0500	50.0	70.0	139.7	84.0	41.50	37.1	14.0
0530	53.0	73.0	146.0	89.0	41.50	37.1	18.0
0540	54.0	73.0	146.0	89.0	41.50	37.1	18.0
0550	55.0	73.0	146.0	89.0	41.50	37.1	18.0
0580	58.0	79.4	165.1	97.0	43.10	37.1	18.0
0600	60.0	82.5	165.1	97.0	43.10	37.1	18.0
0630	63.0	85.7	165.1	101.0	44.70	41.2	18.0
0650	65.0	88.9	177.8	103.0	44.70	41.2	18.0
0680	68.0	92.0	177.8	111.0	46.20	41.2	18.0

DIMENSIONS FOR HIGHER SIZES AVAILABLE ON REQUEST

DESIGN VARIATIONS

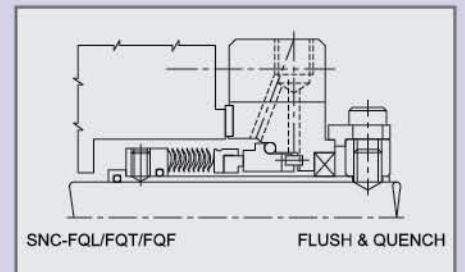
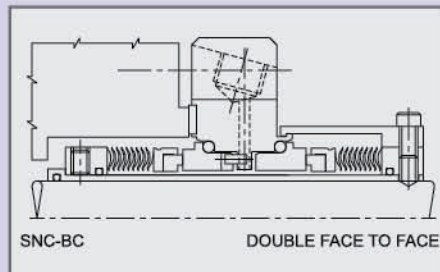
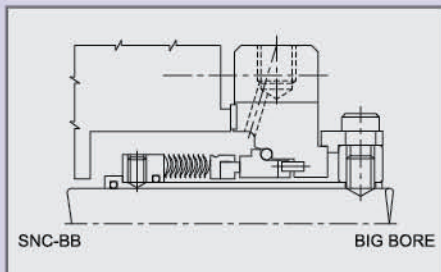

Due to continuous improvement specifications & dimensions may change without prior notice